

## INDIAN INSTITUTE OF MANAGEMENT SIRMAUR

भारतीय प्रबंध संस्थान सिरमौर

Dhaura Kuan, Distt. Sirmaur  
Himachal Pradesh – 173031, India

धौला कुआँ, जिला. सिरमौर  
हिमाचल प्रदेश - 173031, भारत

संख्या | No. IIMS/PUR/Professor Desk/05/26-27

दिनांक | Date: 05.05.2026

### भाव-पत्र आमंत्रण | Request for Quotation

सेवा में | To,  
प्रशासनिक अधिकारी (क्रय) | Administrative Officer (Purchase),  
भारतीय प्रबंध संस्थान सिरमौर | Indian Institute of Management Sirmaur  
धौला कुआँ, सिरमौर, 173031 | Dhaura Kuan, Sirmaur, 173031

विषय: आईआईएम सिरमौर, हिमाचल प्रदेश में कक्षाओं हेतु प्रोफेसर डेस्क के निर्माण, आपूर्ति एवं स्थापना के लिए ई-कोटेशन आमंत्रण।

**Subject: Call for e-quotations for Manufacturing, Supply and fixing of Professor Desk for Classrooms at IIM Sirmaur, H.P.**

आईआईएम सिरमौर, हिमाचल प्रदेश में कक्षाओं हेतु प्रोफेसर डेस्क के निर्माण, आपूर्ति एवं स्थापना के लिए आपसे पासवर्ड-संरक्षित ई-कोटेशन आमंत्रित किए जाते हैं।

We solicit your password protected e-quotation for Manufacturing, Supply and fixing of Professor Desk for Classrooms at IIM Sirmaur, H.P.

Quotation Format (On letter Head Only)				
Sr. No	Description of Service	Quantity	Unit Price (Incl. of GST & all) In INR	Total Cost (Incl. of GST & all) In INR
01	<b>Manufacturing, Supply and fixing of Professor Desk for Classrooms at IIM Sirmaur, H.P. in the Building:</b>	23 Nos.	To be filled by the vendor on their letter head	To be filled by the vendor on their letter head
	a) MDP Classroom (03 Nos.)			
	b) Classroom Complex-II (08 Nos.)			
	c) Classroom Complex-I (10 Nos.)			
d) Examination Hall (02 Nos.)				
<b>Grand Total Amount (Inclusive of Taxes, FOR &amp; all other charges)</b>				To be filled by the vendor on their letter head

#### NOTE:

1. **Specifications** of the above-mentioned Professor Desk are attached at *Annexure-I*.
2. **Drawing** of the Professor Desk is attached at *Annexure-II*.
3. **Reference Picture** of the Professor Desk is attached at *Annexure-III*.

#### **A. Instructions to the participants:**

1. The bidders have to send this RFQ after filing rates on their letter head in password protected pdf format only to IIM Sirmaur by emailing to [purchaseoffice@iimsirmaur.ac.in](mailto:purchaseoffice@iimsirmaur.ac.in) with subject line:  
**Quotation for Manufacturing, Supply and fixing of Professor Desk for Classrooms at IIM Sirmaur, H.P.**  
Kindly ensure that the quotation is signed & stamped in the .pdf format (Password protected), and free from any virus or corrupted files.
2. Quotation received without password protected shall not be considered for further process.

3. Quotations should be submitted on or before **02:00 PM by 14.05.2026 (Thursday)** and the password has to be shared between **02:30 PM to 03:00 PM** on the same date on [purchaseoffice@iimsirmaur.ac.in](mailto:purchaseoffice@iimsirmaur.ac.in) email.

4. **The Bidder is required to submit the following documents/undertakings, duly signed and stamped on the firm's official letterhead, along with the quotation:**

**a) GSTIN and PAN Documents:**

Self-attested copies of the firm's GSTIN and PAN.

**b) Undertaking regarding Blacklisting(Annexure – IV):**

Name of the Firm: \_\_\_\_\_

The bidder should not have been debarred/blacklisted by any Government Department, Semi-Government Department, Educational Institution (including IIMs), or any other organization during the last five (05) years.

**c) Undertaking for Acceptance of Terms & Conditions (Annexure – V):**

Name of the Firm: \_\_\_\_\_

The bidder should confirm that all terms and conditions of the RFQ have been read carefully and are acceptable, and that the work will be executed strictly in accordance with the specification mentioned in Annexure – I.

**d) Work Experience:**

The firm should have satisfactorily completed any classroom furniture works during the last Three (03) years in Central Government/State Government/Autonomous Bodies/Educational Institutions such as IIMs, IITs, Central Universities, NITs, etc.

Self-attested copies of Work Orders and Completion Certificates must be submitted. The bidder should meet **any one** of the following criteria:

- Three (03) similar completed works, each costing not less than ₹2.65 lakh

OR

- Two (02) similar completed works, each costing not less than ₹4.00 lakh

OR

- One (01) similar completed work costing not less than ₹5.30 lakh

**e) OEM Authorization:** The bidder should be an Original Equipment Manufacturer (OEM) of wooden furniture or an authorized dealer/partner of the OEM.

**f) Warranty:** Minimum warranty of 03 (three) years must be provided for the supplied items.

**g) ISO Certification:** A valid ISO certification of the firm must be submitted.

5. The selected vendor has to provide the services as per specifications.
6. Payment shall be made to the successful vendor within 30 working days after successful completion of work of Manufacturing, Supply and fixing of Professor Desk for Classrooms at IIM Sirmaur, H.P.
7. The vendor may visit, if required, on 11<sup>th</sup> or 12<sup>th</sup> May, 2026 between 10:00 AM and 05:00 PM to examine the existing Professor Desk (including its dimensions, shape, and materials used) located in the MDA Classroom of the MDP Building at IIM Sirmaur, Permanent Campus, Dhaula Kuan, District Sirmaur, H.P., for better understanding of the work. A project office representative shall assist.



7. Note: Kindly submit the password protected financial quotes on your letterhead only as per the attached RFQ (Request for Quotation) along with the mentioned details & documents, please.

फर्म का नाम/Name of Firm \_\_\_\_\_

फर्म का पता/Address of the Firm \_\_\_\_\_ To be filled

जीएसटीआईएन/GSTIN \_\_\_\_\_ by the

पैन/PAN \_\_\_\_\_ Vendor on

ईमेल पता/Email Address \_\_\_\_\_ their letter head only

संपर्क नंबर/Contact No. \_\_\_\_\_

  
प्रशासनिक अधिकारी (क्रय)  
भारतीय प्रबंध संस्थान सिरमौर

अधिकृत हस्ताक्षरकर्ता के हस्ताक्षर एवं मोहर / Signature & Stamp of the Authorized Signatory



## Specifications for Professor Desk

\*\*\*\*\*

Manufacturing, supplying, and fixing in position of customised & factory made professor desk with decorative laminate shade as approved by the institute of required size : W-1500mm x D-900mm x H-700mm + 190 mm. Table drawing and images is attached with tender document for reference.

Table top shall be made out of 38 mm thick commercial ply wood of BWP Grade confirming to IS 710:2010 on both side of approved colour and contained the thickness shall be 38mm (12mm Plywood + 12mm baton between both the plywood + 12mm Plywood). For additional strength wooden framing should be provided between both the plywood of table top total 05 numbers vertical baton size 12mm x 25mm x 900 mm length and 04 numbers horizontal baton 12mm x 25mm x 1500 length to be used.

Add on unit made of 19 mm thick commercial play of BWP grade confirming to IS 710:2010 to be provided on the table top to in-house the Display, cable cubby, space for electrical and ICT cables of as shown in the reference image and drawing.

The under structure compartment shall be made out of 19 mm thick commercial ply of BWP Grade confirming to IS 710:2010 shall be supporting below the working table top and front modesty shall have two open able shutter made out of 19mm thick commercial ply of BWP Grade confirming to IS 710:2010 with locking facility. The under structure compartment shall have height of 650 mm to 700 mm fixed over wheel size of minimum 50 mm for easy movement of the table. The under structure compartment be fixed at bottom of table top and all edges of the corner shall be round chamfered.

Table top surface, add on unit, and all sides of under structure shall be pasted with 1.00 mm thick decorative / coloured high pressure laminated sheet with hot pressed EVA glue/ adhesive of approved quality. Balancing Laminate shall be pasted at back side and inner area of table unit of the 0.60 mm thickness in gloss / matt finish with high density protective surface layer pasted with hot pressed eva glue/ adhesive of approved quality.

The working or non-working edges shall be provided with PVC edge bending using with special hot melt EVA glue at hot temperature.

All necessary SS hardware/ fitting/ hinges/ locks/ handles etc. shall be as per ISI standards.

Table shall be provided with tray for Keyboard runs on telescopic channel for smooth operation.

Table shall have adequate provisions for the movement of electric/ data cables at desired levels.

The material procure from FSC certified supplier / OEM and complete as per the direction of Engineer-In-Charge.

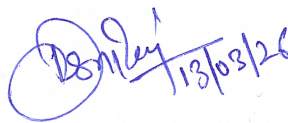
 11/3/2026

# Professor Desk Drawing

Annexure - 11

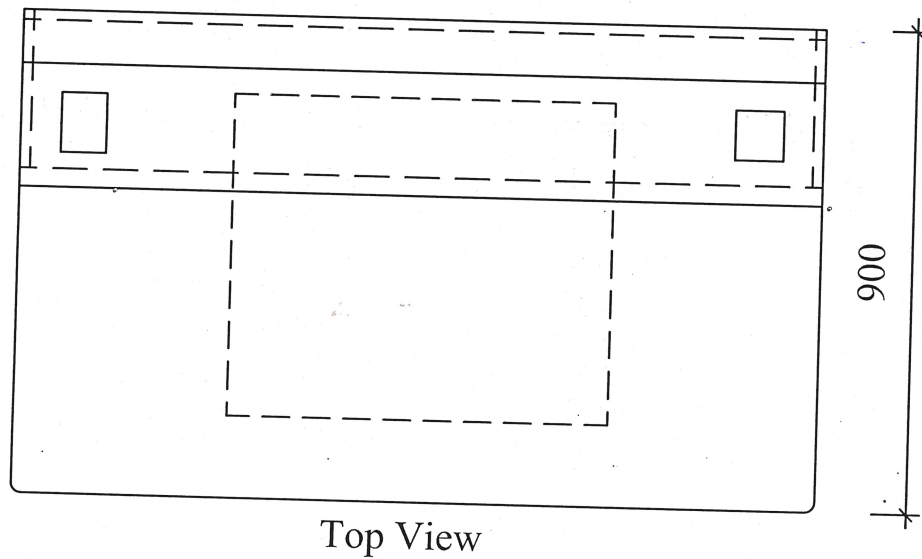
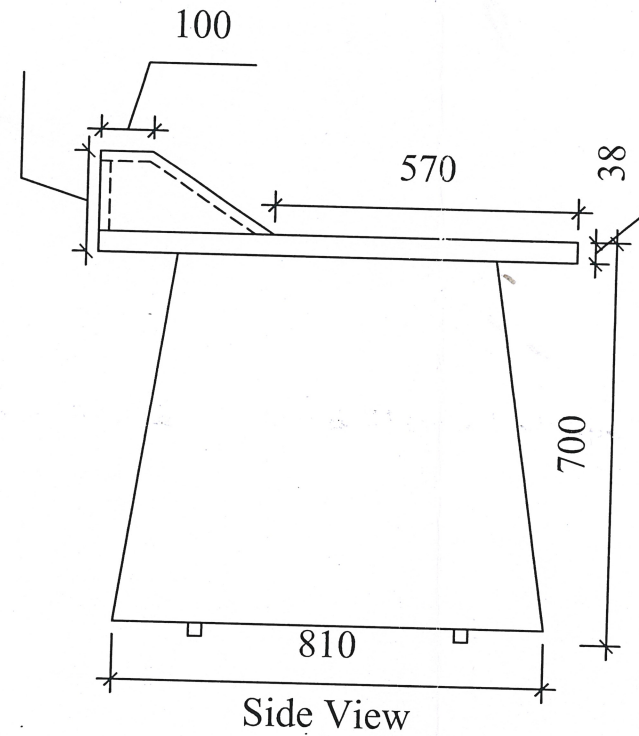
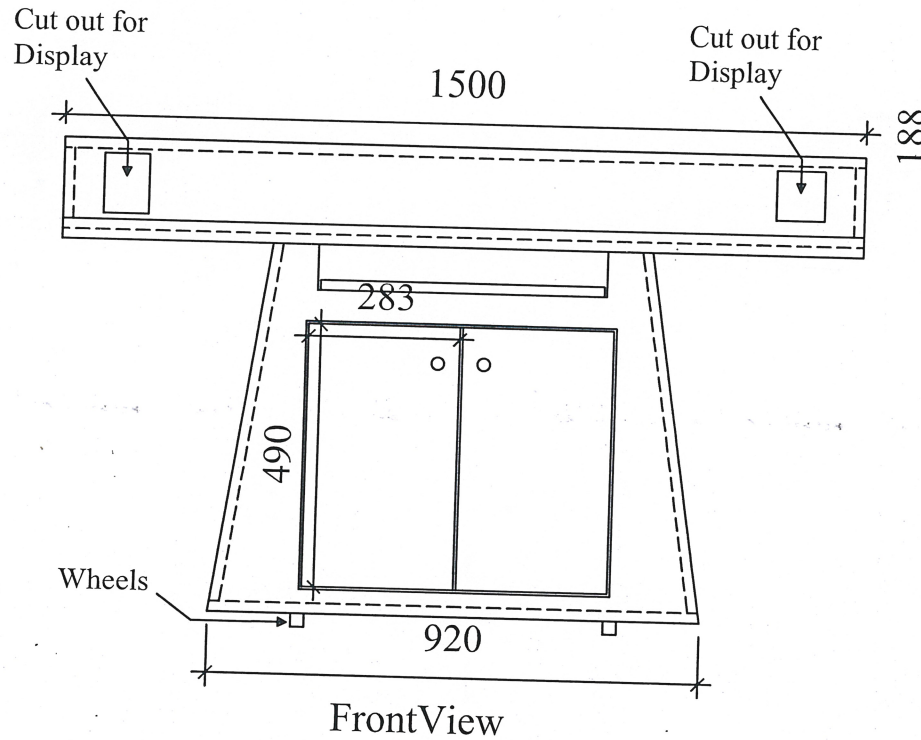

## Note:

1. All edges should be round shaped.
2. Dimension tolerance limit:- +/- 10%
3. Laminate Shade should Match as per existing classroom furniture
4. Wheels to be provided for easy movement
5. Access for Cable entry to be provided at bottom and top raised modesty

13/03/26

Annexure-III



**UNDERTAKING (NON-BLACKLISTING)**

(To be submitted on bidder's letterhead)

To,

The Administrative Officer,  
Indian Institute of Management Sirmaur,  
Dhaura Kuan, Sirmaur, H.P. (173031)

**Subject:** Undertaking regarding non-blacklisting

Sir/Madam,

I/We, **M/s** \_\_\_\_\_, hereby undertake that our firm has **not been debarred or blacklisted** by any Government Department / Semi-Government Department / Educational Institution / IIM / or any other organization during the **last five (05) years**.

Further, I/We declare that the information furnished above is true and correct. In case it is found otherwise, the Institute may take appropriate action as deemed fit.

**Date:** \_\_\_\_\_

**Signature:** \_\_\_\_\_

**Place:** \_\_\_\_\_

**Name:** \_\_\_\_\_

**Annexure – V**

**UNDERTAKING (ACCEPTANCE OF RFQ TERMS & CONDITIONS)**  
(To be submitted on bidder's letterhead)

To,

The Administrative Officer,  
Indian Institute of Management Sirmaur,  
Dhaura Kuan, Sirmaur, H.P. (173031)

**Subject:** Undertaking for acceptance of RFQ terms & conditions

Sir/Madam,

I/We, **M/s** \_\_\_\_\_, hereby declare that I/We have **carefully read and understood all the terms and conditions** mentioned in the RFQ for *Manufacturing, Supply and Fixing of Professor Desk*.

I/We further undertake that **I/We agree to abide by all the terms and conditions** of the RFQ and are **ready to execute the work** as per the specifications and conditions mentioned therein.

Date: \_\_\_\_\_

Signature: \_\_\_\_\_

Name: \_\_\_\_\_

Seal of Firm: \_\_\_\_\_